

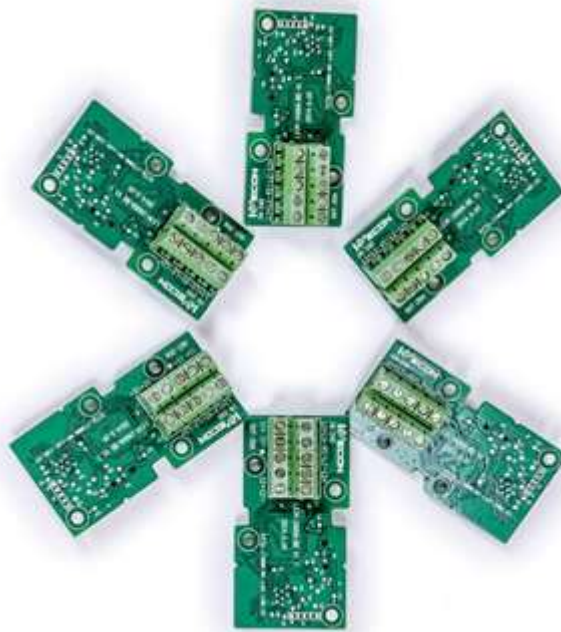

WECON

LX3V-2TC-BD

Module



Website: <http://www.we-con.com.cn/en>

Technical Support: liux@we-con.com.cn

Skype: “fcwkkj” or “Jason.chen842”

Phone: 86-591-87868869

QQ Group: 465230233

Technical forum: <http://wecon.freeforums.net/>



1. Mounting instruction

Before the installation must be ensure that the PLC host and BD associated equipment power off. Please install the BD module in the corresponding position of the PLC, and lock the four standard screws. If environmental dust is bigger, please cover BD right part by PLC's cover. Please do not power operation.

Caution

- 1) This BD module only support the following firmware versions or later. Users can check the PLC firmware version in D8001.
 - LX3VP:25103;
 - LX3V-A2:25015;
 - LX3V-LX3VE:25201;
 - A1:22007;
 - LX2VA:24006;

When mounting module to PLC, all the lights are blinking after power ON PLC please upgrade the firmware of PLC.

- 2) Please fixed BD module on the PLC, poor contact may lead to failure.
- 3) BD module and top cover of PLC's tightening torque is 0.3 ~ 0.6 N.m.

Warning

Make sure to power off the PLC before mounting or removing the BD module and put the cover in right place.

2. Special feature

- 1) LX3V-2TC-BD module equips with 2 channels analog output. This module will be mounted in the PLC, so there is no need to change the installation area of the PLC.
- 2) The type to AD convert of LX3V-2TC-BD is a thermocouple input type (K/J), and the converted digital value of each channel is stored in special registers, but the mode of analog-to-digital conversion cannot be changed. The corresponding channel as following table shows.

Table 2-1 LX3V-2TC-BD address assignment

Extension port 1 (far away from PLC LED)		Extension port 2 (near PLC LED)	
Address	Description	Address	Description
M8112	The flag of thermocouple switch in CH1 OFF: K type ON: J type	M8116	The flag of thermocouple switch in CH1 OFF: K type ON: J type

M8113	The flag of thermocouple switch in CH2 OFF: K type ON: J type	M8117	The flag of thermocouple switch in CH1 OFF: K type ON: J type
D8112	CH1 temperature (unit: 0.1)	D8116	CH1 temperature (unit: 0.1)
D8113	CH2 temperature (unit: 0.1)	D8117	CH2 temperature (unit: 0.1)

3. Dimension

Table 3-1

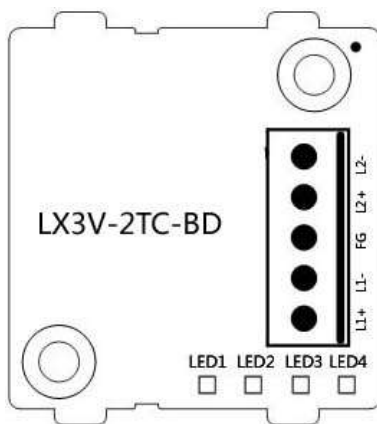

Applied sensor: 2-wire thermocouple(K/J)	
L1+	Positive pole of CH1's sensor
L1-	Negative pole of CH1's sensor
FG	None
L2+	Positive pole of CH2's sensor
L2-	Negative pole of CH2's sensor

LED lights indicating

- 1) LED1: ON when power ON.
- 2) LED2: flashes when communications.
- 3) LED3 (TC 1): On indicates enable, OFF indicates disable, flicker indicates exceeding the measurement range.
- 4) LED4 (TC 2): On indicates enable, OFF indicates disable, flicker indicates exceeding the measurement range.

If the BD module is plugged into the old firmware version when on the host, all LEDs will be flashing.

4. Specifications

- 1) Please refer to the LX3V user manual for the general specification of LX3V-2TC-BD.
- 2) LX3V-2TC-BD is powered supply by LX3V main unit.

Table 4-1

Item	Explanation
Analog circuitry	DC 24V \pm 10%, 70mA
Digital circuitry	DC 5V, 90mA (From the PLC internal power supply)

Temperature	Read data by buffers			
Analog input signal	Thermocouple: K or J type (2 channels)			
Range of rated temperature	K	-100°C - 1200°C	J	-100°C - 600°C
Digital output	K	-1000 - 12000	J	-1000 - 6000
	12 bits total			
Accuracy	K	0.4°C	J	0.3°C
Overall accuracy	±0.5%			
Conversion rate	50ms*2			
Conversion characteristics	<p>The graph plots Digital output against Temperature Input. For K type, the output ranges from -1000 at -100°C to +12000 at +1200°C. For J type, the output ranges from -1000 at -100°C to +6000 at +600°C.</p>			

Note: Ground-type thermocouple (3-wire) is not supported in this BD module.

5. Wire

Warning

Make sure cut off the electricity before installation/disassembly, to prevent electric shock or product damages.

Caution

- 1) Stay away from high-voltage cables to avoid interference or surge;
- 2) Grounding is required, but please do not share the ground site with high-voltage cable;
- 3) Do not weld any cable ends, and make ensure that the number of connecting cables, no more than a predetermined number;
- 4) Do not connect a substandard cable;
- 5) Fixed cable;

5.1 Suitable cable

Use AWG25-16 to connect the output equipment

The maximal screwing torque is from 0.5 to 0.6N.m

Table 5-1

Line type	Cross sectional area(mm ²)	End-of-pipe treatment

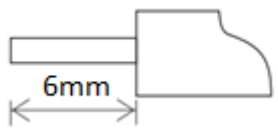
AWG26	0.1288	Stranded cable: stripped jacket, rub Conductor, then connect the cable.	
.....		
AWG16	1.309	Single-core cable: stripped jacket, Then connect the cable.	

5.2 Input

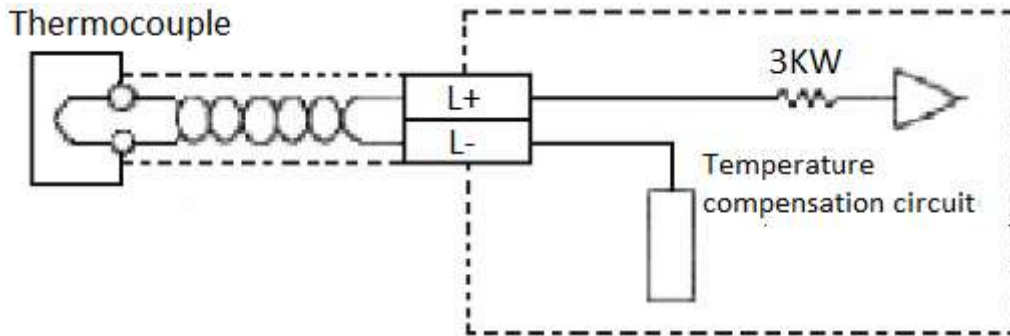

Figure 5-1

6.Examples

The analog values of each channel are transfer to digital values and stored in D8112&D8113.

6.1 Basic Program Examples

Set CH1 and CH2 as thermocouple input mode, and stored value in D0 and D2.

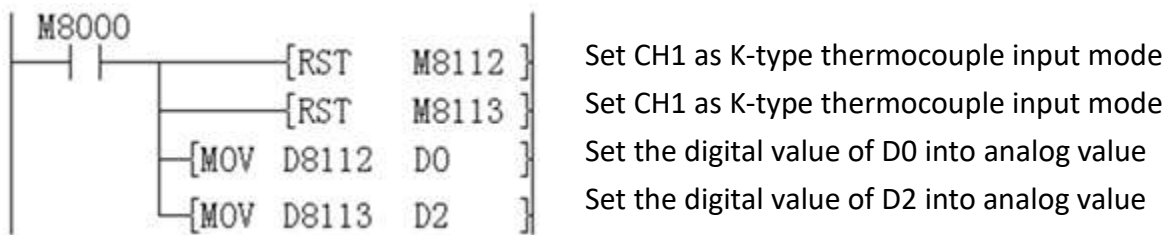

6.2. Examples of Applications

Since the LX3V-2TC-BD does not have offset and gain functions, if it needs for the values out of the standard specifications, Additional programming orders will be needed to multiply or divide the converted value.

Caution

Since the use of additional programming orders, the converted precision and resolution of the analog

value are different with the specifications.

The original range of the analog output does not change.

Thermocouple input mode

In Thermocouple input mode, LX3V-2TC-BD convert an analog value to a digital value in degrees Celsius. If in the program is Fahrenheit as a unit it needs to be converted to Celsius value.

Fahrenheit and Celsius conversion formula, Fahrenheit = Celsius * 9/5 + 32, the unit is 0.1 °C.

$$D10 = D8112 * 9$$

$$D12 = D10 / 5$$

$$D0 = D12 + 320$$

$$D0 = D8112 * 9 / 5 + 320$$

