

# **WECON LX3V-4TC Module 2015**



**Wecon Technology Co.Ltd.,**

SITE: <http://en.we-con.com.cn>

Technical Support: [liux@we-con.com.cn](mailto:liux@we-con.com.cn)

Skype: fcwkkj    PHONE: 86-591-87868869

# LX3V-4TC Extension module

## 1.Introduction

The LX3V-4TC analog block amplifies the signal from four thermocouple sensors (Type K or J) and converts the data into 16 bit reading's stored in the main unit. Both Centigrade (°C) and Fahrenheit(°F) can be read.

Reading resolution is 0.4°C/0.72°F of Type K and 0.3°C/0.54°F of Type J.

The LX3V-4TC can connected to the LX3V series Programmable Logic Controllers (PLC).

All data transfers and parameter settings are adjusted via software control of the LX3V-4TC; by use of the TO/FROM applied instructions in the PLC.

LX3V-4TC consume 5V voltage from LX3V main unit or active extension unit,90mA current of power supply.Thermocouples with the following specifications can be used:Type K, Type J.

## 2. External dimensions

Weight:Approx 0.3kg (0.661bs)

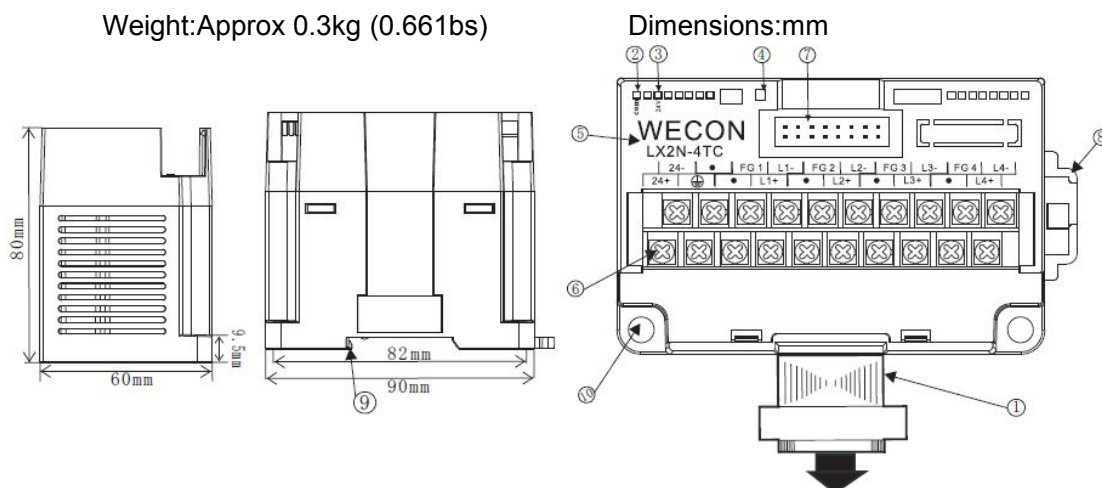

- ① Extension cable and connector
- ② Com LED:Light when communicating
- ③ Power LED:Light when connect to 24V
- ④ State LED:Light when normal condition
- ⑤ Module name
- ⑥ Analog signal output terminal
- ⑦ Extension module interface
- ⑧ DIN rail mounting slot
- ⑨ DIN rail hook
- ⑩ Mounting holes(φ4.5)

### 2.1Using crimp terminations

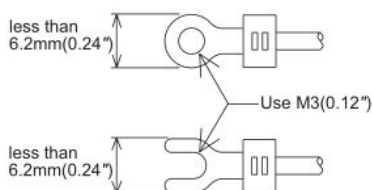

- Use crimp terminals as indicated on the left.
- The tightening torque must be 0.5 and 0.8 N-m. Do not tighten terminal screws exceeding the specified torque. Failure to do so may cause equipment failures or malfunctions.
- Wire only to the module terminals discussed in this manual. Leave all others vacant.

### 3.Wiring

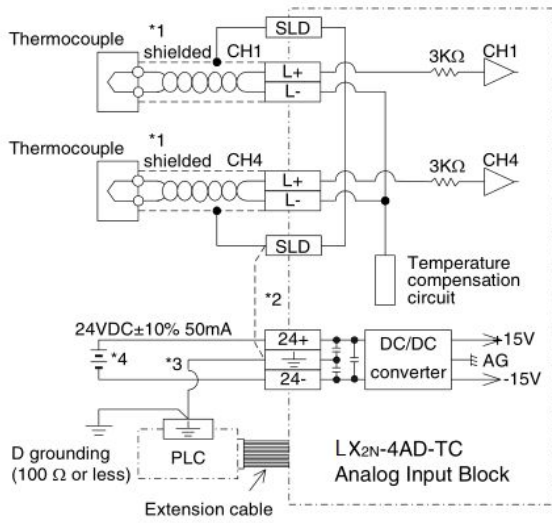

\*1: The compensating cables that can be used for connecting with the thermocouple are the following.  
 Type K: KX-G, KX-GS, KX-H, KX-HS, WX-G, WX-H, VX-G  
 Type J: JX-G, JX-H  
 For every 10Ω of line resistance, the compensating cable will indicate a temperature 0.12°C higher than actual.  
 Check the line resistance before using.  
 Long compensating cables are more prone to noise interference, therefore a short (less than 100m) compensating cable is recommended.  
 Unused channels should have a wire link connected between the + and - terminals to prevent an error being detected on that channel.

\*2: If there is excessive electrical noise, connect the SLD terminal to the ground terminal on the unit.

\*3: Connect the ground terminals of the LX2N-4AD-TC unit and the main unit. Use grounding on the main unit.

\*4: The 24V DC built-in supply of the PLC may be used as the power supply.

### 4.Installation environment

#### 4.1 Environment specification

Item	Description
Environment specification	Same as those for the main unit
Dielectric withstand voltage	500V AC, 1min (between all terminals and ground)

#### 4.2 Power supply specification

Item	Description
Analog circuit	24V DC ± 10%, 50mA
Digital circuits	5V DC, 90mA (internal power supply from the main unit)

#### 4.3 Performance specification

Analog output

Item	Centigrade (°C)		Fahrenheit (°F)	
	Both °C and °F are available by reading the appropriate buffer memory(BFM).			
Input signal	Thermocouple: Type K or J (either can be used for each channel), 4 channels,			
Rated temperature range	Type K	-100°C to +1200°C	Type K	-148°F to +2192°F
	Type J	-100°C to +600°C	Type J	-148°F to +1112°F
Digital output	Type K	-1000 to 12000	Type K	-1480 to 21920
	Type J	-1000 to 6000	Type J	-1480 to 11120
Resolution	12-bit conversion, save as complement of 2 in 16 bits			
	Type K	0.4°C	Type K	0.72°F
	Type J	0.3°C	Type J	0.54°F
Overall accuracy	± (0.5% full scale +1°C) Freezing point of pure water 0°C / 32°F			
Conversion speed	(240ms ± 2%) × 4 channels (unused channels are not converted)			

**Note:** Earth-tipped thermocouples are not suitable for use with this unit.

Analog input continued.....

Item	Centigrade (°C)	Fahrenheit (°F)
<b>Conversion Characteristics</b> Readings given at calibration reference point 0°C/32°F (0/320) respectively. (subject to the overall accuracy)		

**Note:** Preset ranges are selected by an appropriate setting in buffer memory of the analog block. Current/Voltage input selection must match the correct input terminal connections.

### Miscellaneous

Item	Description
Isolation	Photo-coupler isolation between analog and digital circuits. DC/DC converter isolation of power from main unit. No isolation between analog channels.
Number of occupied I/O points	The block occupies 8 I/O points (can be either inputs or outputs)

### 4.4 Buffer memories

BFM	Content
*#0	Thermocouple Type K or J selection mode. At shipment: H0000
*#1→#4	CH1 to CH4 Averaged temperature reading to be averaged (1 to 256) Default = 8
*#5→#8	CH1 to CH4 Averaged temperature in 0.1°C units
*#9→#12	CH1 to CH4 Present temperature in 0.1°C units
*#13→#16	CH1 to CH4 Averaged temperature in 0.1°F units
*#17→#20	CH1 to CH4 Present temperature in 0.1°F units
*#21→#27	Reserved
*#28	Digital range error latch
#29	Error status
#30	Identification code K2030
#3	Software

The LX3V-4TC communicates with the PLC via buffer memories.

BFM's #21 to #27 and #31 are reserved.

All non reserved BFM's can be read by the PLC using the FROM instruction.

BFM's (buffer memories) marked with an "\*" can be written to, the special function block using the TO instruction.

#### (1) Buffer Memory BFM #0: Thermocouple Type K or J selection mode

BFM #0 is used to select Type K or J thermocouples for each channel. Each digit of a 4 digit hexadecimal number corresponds to one channel, the least significant digit being channel 1.

#### [ Example ]

H3310

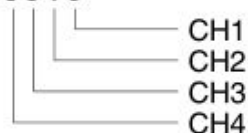

0 = K type  
1 = J type  
3 = Not used

(1) A/D conversion time is 240ms per channel. When "3" (unused) is set for a channel, A/D conversion is not executed for that channel, therefore, the total conversion time is decreased. In the above example, the conversion time is as follows:

240ms (conversion time per channel) × 2channels (number of channels used) = 480ms (total conversion time)

(2) Buffer Memory BFM's #1 to #4: Number of temperature readings to be averaged

When the number of temperature readings to be averaged is specified for BFM's #1 to #4, the averaged data is stored in BFM's #5 to #8 (°C) and #13 to #16 (°F). Only the range 1 to 256 is valid for the number of temperature readings to be averaged. If a value outside of this range is entered, a default value of 8 is used.

(3) Buffer Memory BFM's #9 to #12 and #17 to #20: Present temperature

These BFM's store the present value of the input data. This value is stored in units of 0.1°C or 0.1°F, but the resolution is only 0.4°C or 0.72°F for Type K and 0.3°C or 0.54°F for Type J.

## 5. Status Information

### (1) Buffer Memory BFM #28: Digital range error latch

BFM #29 b10(digital range error) is used to judge whether the measured temperature is within the unit's range.

BFM #28 latches the error status of each channel and can be used to check for thermocouple disconnection.

b15 or b8	b7	b6	b5	b4	b3	b2	b1	b0
Not used	High	Low	High	Low	High	Low	High	Low
	CH4		CH3		CH2		CH1	

Low : Latches ON when the temperature measurement data drops below the lowest temperature limit.

High : Turns ON when the temperature measurement data rises above the highest temperature limit, or when a thermocouple is disconnected.

When an error occurs the temperature data before the error is latched. If the measured value returns to within valid limits the temperature data returns to normal operation. (Note: The error remains latched in (BFM #28))

An error can be cleared by writing K0 to BFM #28 using the TO instruction or turning off the power.

### (2) Buffer Memory BFM #29: Error status

Bit devices of BFM #29	ON	OFF
b0:Error	When either b2 or b3 is ON A/D conversion is stopped for the error channel	Not error
b1:Reserved	Reserved	Reserved
b2:Power source failure	24V DC power supply failure	power supply normal
b3:Hardware error	A/D converter or other hardware failure	Hardware error
b4 to b9:Reserved	Reserved	Reserved
b10:Digital range error	Digital output/analog input value is outside the specified range.	Digital output value is normal.
b11:Averaging number error	Selected number of averaged results is outside the available range -see BFM #1 to #4	Averaging is normal. (between 1 to 256)
b12 to b15:Reserved	Reserved	Reserved

### (3) Identification Code Buffer Memory BFM #30

The identification code or ID number for this Special Block is read from buffer memory BFM #30 using the FROM instruction. This number for the LX3V-4TC unit is K2030. The PLC can use this facility in its program to identify the special block before commencing data transfer to and from the special block.

## 5. System Block diagram

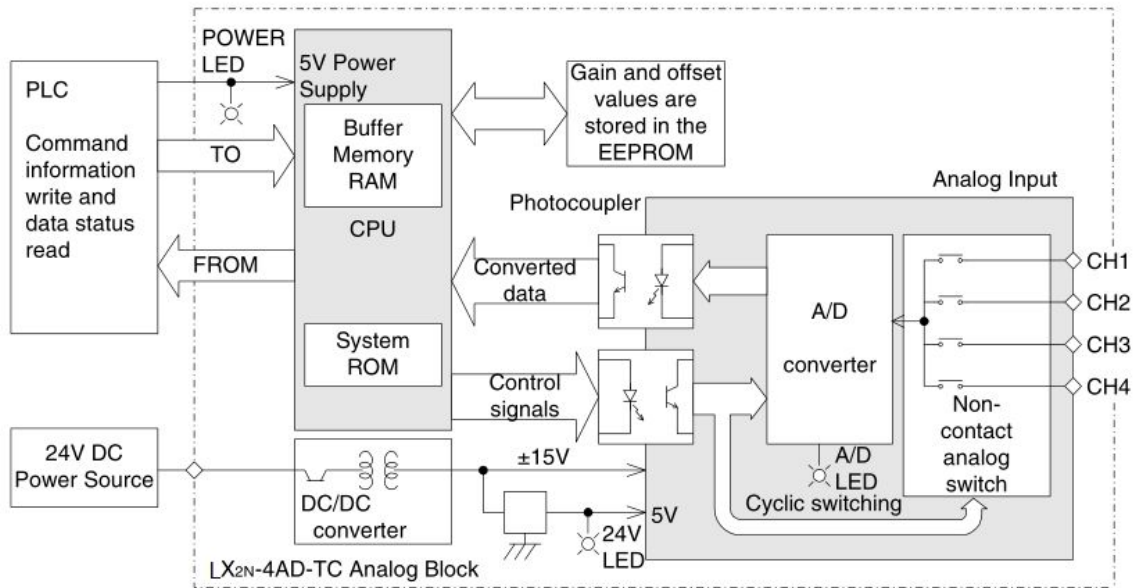

## 6. Example program

In the program shown below, the LX3V-4TC occupies the position of special block number 2 (that is the third closest block to the PLC). A Type K thermocouple is used on CH1 and a Type J on CH2. CH3 and CH4 are not used. The averaging count is four. The averaged values in degrees C of input channels CH1 and CH2 are stored respectively in data registers D0 and D1.

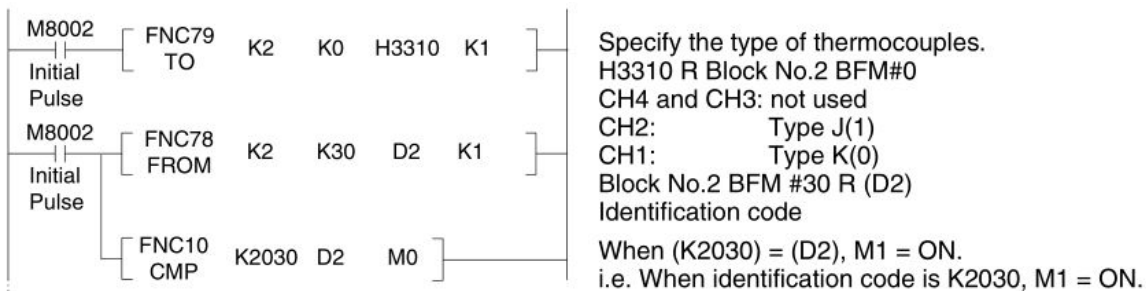

This initial step checks that the special function block placed at position 2 is actually an LX3V-4TC, i.e. its unit identification number is 2030 (BFM #30). This step is optional, but it provides a software check that the system has been configured Correctly.

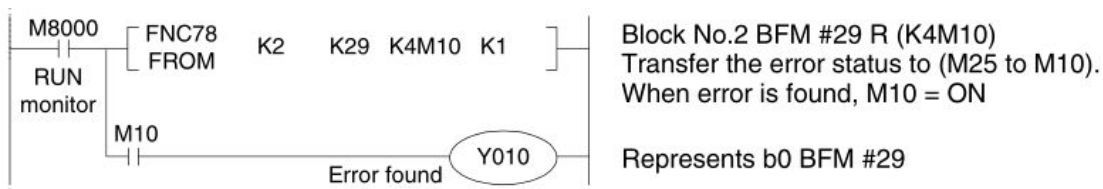

This step provides optional monitoring of the LX3V-4TC Error Buffer Memory (#29). If there is an Error on the LX3V-4TC, bit b0 of BFM #29 will be set on. This can be read by this program step, and output as a bit device in the PLC (Y010 in this example). Additional Error devices can be output in a similar manner, e.g. b10 BFM #29 Digital range error. (see below)



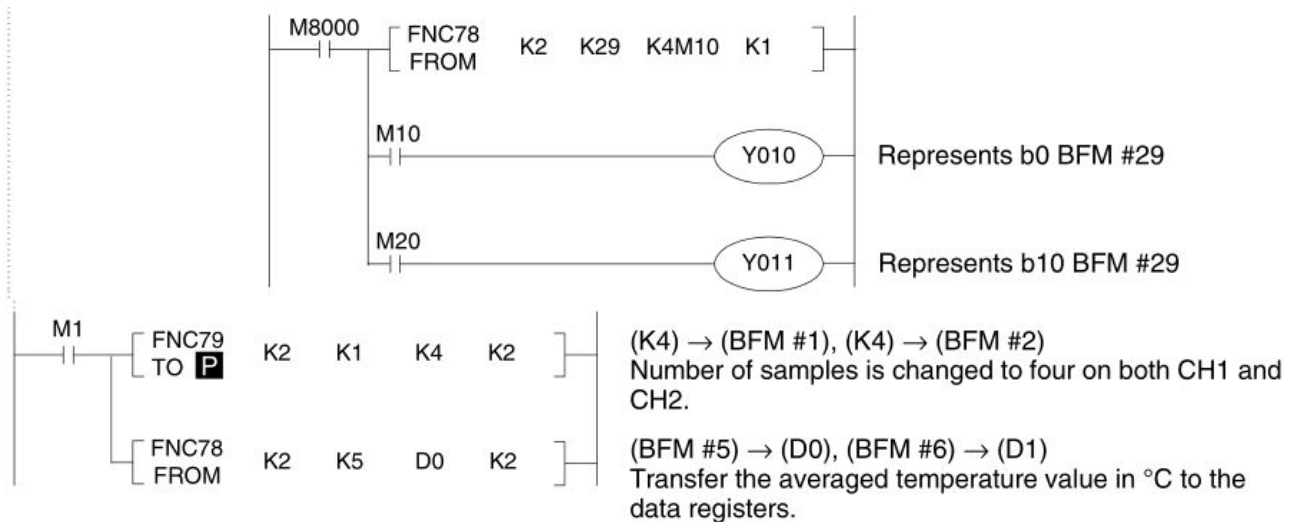

- This step is the actual reading of the LX3V-4TC input channels. It is essentially the only program step which is needed. The "TO" instruction in this example, sets the input channels, CH1 and CH2, to take the average reading of four samples.
- The "FROM" instruction reads the average temperatures (BFM #5 and #6) for input channels CH1 and CH2 of the LX3V-4TC. If direct temperature readings are required BFM #9 and #10 should be read instead, e.g.

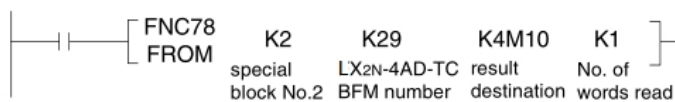

## 7. Diagnostics

### 7.1 Preliminary check

- Check whether the input/output wiring and/or extension cables are properly connected on the LX3V-4TC analog special function block.
- Check that the PLC system configuration limits have not been exceeded, i.e. the number of special function blocks and the total system I/O are within the specified range.
- Ensure that the correct operating range has been selected for the application.
- Check that there is no power overload on either the 5V or 24V power sources, remember the loading on the main unit or a powered extension unit varies according to the number of extension blocks or special function blocks connected.
- Make sure that the main unit has been switched to RUN

### 7.2 Error checking

If the LX3V-4TC special function block does not seem to operate normally, check the following items.

- Check the status of the POWER LED.

Lit: The extension cable is properly connected.

Otherwise : Check the connection of the extension cable.

- Check the external wiring.

- Check the status of the "24V" LED (top right corner of the LX3V-4TC).

Lit: LX3V-4TC is ON, 24V DC power source is ON.

Otherwise : Possible 24V DC power failure, if ON possible LX3V-4TC failure.

- Check the status of the "A/D" LED (top right corner of the LX3V-4TC).

Lit: A/D conversion is proceeding normally.

Otherwise : Check buffer memory #29 (error status). If any bits (b0, b2, b3) are ON, then this is why the A/D LED is OFF.

### 7.3 Checking special function block numbers

Other special units of blocks that use FROM/TO commands, such as analog input blocks, analog output blocks and high-speed counter blocks, can be directly connected to the base unit of the LX3V programmable controller or to the right side of other extension blocks or units. Each special block is consecutively numbered from 0 to 15 beginning from the one closest to the base unit. A maximum of eight special blocks can be connected.

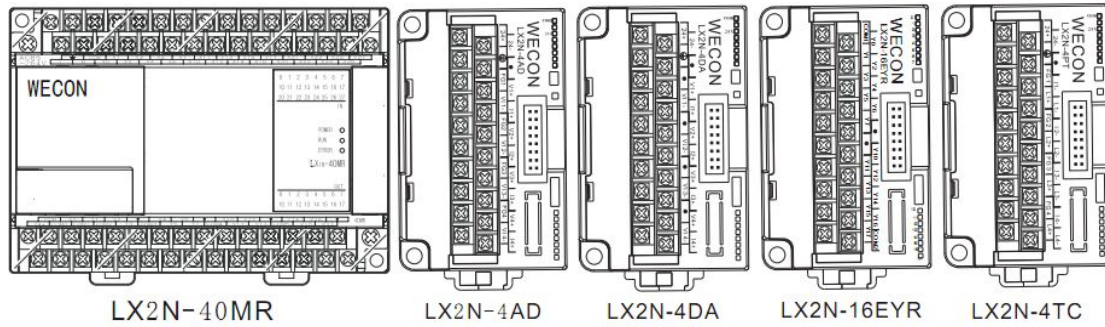

## 8. EMC considerations

- Electromagnetic compatibility or EMC must be considered before using the LX3V-4TC.
- We recommend that the thermocouple sensors used, should be fitted with a form of shield or screening as protection against EMC noise.
- If some form of cable protection is used, the “Shield” must be terminated at the terminals as shown in chapter 2.
- Because of the delicate nature of all analog signals, failure to take good EMC precautions could lead to
- EMC noise induced errors; up to  $\pm 10\%$  of actual values. This is an absolute worst case figure, users who do take good precautions can expect operation within normal tolerances.
- EMC considerations should include selection of good quality cables, good routing of those cables away from potential noise sources.
- Additionally it is recommended that signal averaging is used as this will reduce the effects of random noise “spikes”.